

PROJECT: \_\_\_\_\_  
 CATALOG #: \_\_\_\_\_  
 FIXTURE TYPE: \_\_\_\_\_  
 NOTES: \_\_\_\_\_

# WMC Selectable Wall Pack Medium Contractor Series



DLC 5.1  
Pending



## PERFORMANCE INFORMATION

LUMEN PACKAGE	SERIES NUMBER	ADJUSTABLE WATTAGE	LUMENS	SELECTABLE CCT
LS1	WMC LS1 G2 FSK	LV1 - 26W	3,860	3000K 4000K 5000K
		LV2 - 41W	5,400	
		LV3 - 55W	6,850	
		LV4 - 67W	7,900	
LS2	WMC LS2 G2 FSK	LV1 - 39W	5,550	
		LV2 - 62W	8,260	
		LV3 - 88W	10,700	
		LV4 - 100W	11,500	

The *Selectable Wall Pack Medium Contractor Series Gen 2* offers maximum light output for general purpose area and security lighting in a classic design. This luminaire features 3 Selectable Color Temperatures and 4 Lumen/Wattage Adjustable Levels. The luminaire efficiently delivers lumens and consumes less energy than traditional wall mount technologies.

### APPLICATIONS

Security Lighting, Perimeter Lighting, Building Entrances, Walkways, etc.

### REPLACEMENT

100W - 250W MH

### OPTIONS



PC UNV B3

Power and  
CCT controller

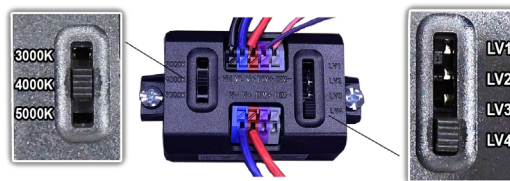

### SELECTABLE CCT

3000K  
4000K  
5000K

### LUMEN ADJUSTABLE

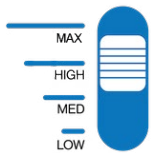

## ORDERING GUIDE

EXAMPLE: WMC 50 G1 5K

Luminaire Type	Lumen Output	Generation	Voltage	Selectable CCT	Finish	Options
<b>WMC</b> Medium Wall Pack Contractor Series	<b>LS1</b> 3860/5400/6850/7900 Lumens - 26W / 41W / 55W / 67W <b>LS2</b> 5550/8260/10700/11500 Lumens - 39W / 62W / 88W / 100W	<b>G2</b>	<b>BLANK</b> 120-277V	<b>FSK</b> 3000K/4000K /5000K	<b>BLANK</b> Dark Bronze	<b>BLANK</b> No Option <b>PC UNV B3</b> Button Photocell

\*For a custom color, please call to place your order

Due to continuous product improvements, specification and/or equipment updates may change without notice.

## SPECIFICATIONS

### HOUSING

Die-cast aluminum housing and back-housing.

### AMBIENT TEMPERATURE

Suitable for use in  $-40^{\circ}\text{C}$  to  $+40^{\circ}\text{C}$  ( $-40^{\circ}\text{F}$  to  $104^{\circ}\text{F}$ )

### MOUNTING

Mounting options include J-Box mounting and Wall mounting, wiring made-up before the lens and front housing.

### EFFICACY

Up to 122 lumens per watt (see individual wattage data)

### CCT AND CRI

Selectable 3000K, 4000K, and 5000K CCT available; 70CRI

### OPTICS

Polycarbonate optical lens with UV stabilizers.

### WARRANTY

5-year limited warranty. Comprehensive warranty terms can be located on [www.slgus.com](http://www.slgus.com).

### ELECTRICAL

High quality constant-current drivers >90% efficiency and rated for 50/60Hz operation with Standard 120-277V input.

### ENERGY DATA

Power factor  $\geq 90\%$ .

### FINISH

Polyester Powder Dark Bronze coat.

### CERTIFICATIONS

UL Listed for wet locations. Equivalent to IP65 rating. FCC compliant. RoHs compliant. Design Lights Consortium® (DLC) 5.1 pending product. Please visit [www.slgus.com](http://www.slgus.com) to confirm which versions are qualified.

## DIMENSIONS

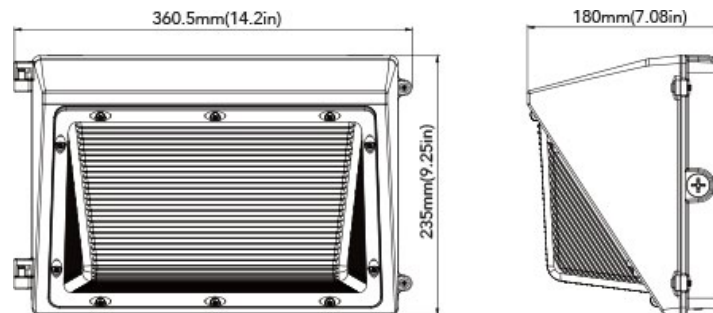

Net Weight  
WMC LS1: 6.724lb  
WMC LS2: 7.319lb

Due to continuous product improvements, specification and/or equipment updates may change without notice.

## PHOTOMETRIC

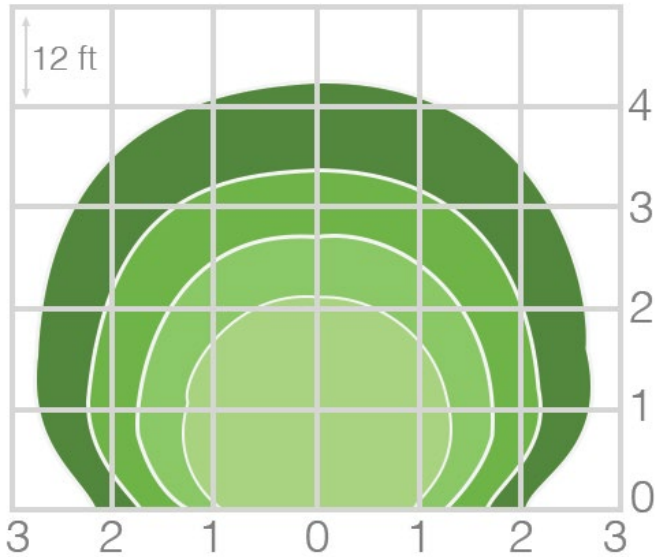

WMC LS1 G2 FSK

Mounting Height	12	14	16	18	20
Multiplier	1.8	1.3	1.0	0.8	0.6

## ELECTRICAL LOAD

Series Number	Wattage	Current (A)			
		120V	208V	240V	277V
WMC LS1 G2 FSK	26W	0.22	0.13	0.11	0.09
	41W	0.34	0.20	0.17	0.15
	55W	0.46	0.26	0.23	0.20
	67W	0.56	0.32	0.28	0.24
WMC LS2 G2 FSK	39W	0.33	0.19	0.16	0.14
	62W	0.52	0.30	0.26	0.22
	88W	0.73	0.42	0.37	0.32
	100W	0.83	0.48	0.42	0.36

Due to continuous product improvements, specification and/or equipment updates may change without notice.